

## 2. MODEL DEVELOPMENT

The first step in studying each experimental source was to develop a two-phase mass balance model describing the rate at which a chemical enters, leaves, or accumulates within the system. A key component of each source model was the rate at which a chemical leaves the liquid phase and enters the gas phase. This volatilization rate may be described in terms of a stripping efficiency or mass transfer coefficient. To determine the volatilization rate for a source, a separate mass balance was completed on each phase. By simultaneously solving the respective differential equations, the source-specific chemical volatilization rate was predicted.

This section is divided into four parts. Section 2.1 involves the theory of mass transfer and important mass transfer parameters. Section 2.2 presents the different mass balance models used for ideal reactors. Section 2.3 describes the mass balance models developed for each experimental system. Finally, Section 2.4 describes the chemical emission models associated with each source.

### 2.1. MASS TRANSFER THEORY

Although the operation of each household tap water source is very different, a similar group of mass transfer parameters may be applied to characterize the volatilization of chemicals. These parameters include chemical stripping efficiency, mass transfer coefficients (overall, liquid-phase, and gas-phase), and the ratio of overall mass transfer coefficients for any two contaminants. Each of these values is discussed in this section.

#### 2.1.1. Chemical Stripping Efficiency

The stripping efficiency of a specific chemical for a flow-through system with a constant volumetric flowrate of water and no reactions is defined as:

$$\zeta = 1 - \frac{C_{l,out}}{C_{l,in}} \quad (2-1)$$

where

- $\zeta$  = stripping efficiency (fractional)
- $C_{l,out}$  = outlet chemical concentration in water (M/L<sup>3</sup>)
- $C_{l,in}$  = inlet chemical concentration in water (M/L<sup>3</sup>).

Similarly, the stripping efficiency of a specific chemical for a batch system with a constant volume of water and no reaction is defined as:

$$\zeta = 1 - \frac{C_{1,end}}{C_{1,0}} \quad (2-2)$$

where

- $\zeta$  = stripping efficiency (fractional)
- $C_{1,end}$  = final chemical concentration in water (M/L<sup>3</sup>)
- $C_{1,0}$  = initial chemical concentration in water (M/L<sup>3</sup>).

In general, a stripping efficiency requires measurement of the inlet liquid concentration to the system of interest and measurement of the outlet liquid concentration at the system's drain. Stripping efficiency values are influenced by several factors, including chemical properties (e.g., Henry's law constant [ $H_c$ ]), temperature, nozzle type, liquid flowrate, gas flowrate, and presence of a person, detergent, clothes, and dishes (depending on the type of source).

### 2.1.2. Mass Transfer Coefficients

Each household source is characterized by a unique combination of mass transfer mechanisms that affect chemical volatilization rates. These mechanisms can include a falling film, (e.g., the jet associated with a faucet), spray droplets (e.g., in showers or dishwashers), splashing at surfaces (e.g., during the filling of a washing machine), and entrained air bubbles (e.g., when a faucet jet impacts an underlying basin). When two or more of these mechanisms are important, it is often difficult or impossible to determine separate mass transfer coefficients. It is common to "lump" the effects of multiple mass transfer mechanisms into a single overall mass transfer coefficient,  $K_L$ . The resulting equation for local rate of change of mass in the liquid phase associated only with volatilization is:

$$h = 1 - \frac{C_{1,out}}{C_{1,in}} \quad (2-3)$$

where

- $C_1$  = chemical concentration in water (M/L<sup>3</sup>)
- $V_1$  = local volume of water (L<sup>3</sup>)
- $t$  = time (T)
- $K_L$  = overall mass transfer coefficient for the chemical of interest (L/T)
- $C_g$  = contaminant concentration in air adjacent to water (M/L<sup>3</sup>)
- $H_c$  = Henry's law constant for chemical of interest (L<sup>3</sup><sub>liq</sub>/L<sup>3</sup><sub>gas</sub>)
- $A$  = interfacial surface area between water and adjacent air (L<sup>2</sup>).

For a dilute aqueous solution, the Henry's law constant for a specific chemical is defined as the ratio of chemical concentration in air to that in water at equilibrium. Values of Henry's law constant are dependent on chemical structure and water temperature. For most volatile organic compounds, the Henry's law constant can be approximated closely as the ratio of chemical vapor pressure to solubility in water. As such, a chemical (e.g., acetone) may be considered relatively volatile in its pure state (high vapor pressure) but also relatively nonvolatile when dissolved in water (miscible in water). The term  $(C_1 - C_g/H_c)$  is the concentration driving force between the liquid and gas phases. As the difference between  $C_1$  and  $C_g/H_c$  decreases, the system approaches chemical equilibrium.

In accordance with two-film theory (Lewis and Whitman, 1924), the overall mass transfer coefficient can be expressed as:

$$\frac{1}{K_L} = \frac{1}{k_l} + \frac{1}{k_g CH_c} \quad (2-4)$$

where

- $K_L$  = overall mass transfer coefficient for the chemical of interest (L/T)
- $k_l$  = liquid-phase mass transfer coefficient (L/T)
- $k_g$  = gas-phase mass transfer coefficient (L/T)
- $H_c$  = Henry's law constant for chemical of interest ( $L^3_{\text{liq}}/L^3_{\text{gas}}$ ).

The term  $1/K_L$  is referred to as an overall resistance to mass transfer. The term  $1/k_l$  is referred to as liquid-phase resistance to mass transfer, and  $1/(k_g CH_c)$  is referred to as gas-phase resistance to mass transfer. For  $k_g CH_c \gg k_l$ , gas-phase resistance to mass transfer is small and the overall mass transfer coefficient is approximately equal to the liquid-phase mass transfer coefficient. This condition is generally true for highly volatile compounds such as radon.

It is often difficult to separate mass transfer coefficients and the interfacial area (A) over which mass transfer occurs. This is particularly true for sources without well-defined or quiescent surfaces, for example, most indoor consumptive water uses. However, by dividing each term by  $1/A$ , Equation 2-4 can be effectively rewritten as:

$$\frac{1}{K_L A} = \frac{1}{k_l A} + \frac{1}{k_g A CH_c} \quad (2-5)$$

where

- $K_L$  = overall mass transfer coefficient for the chemical of interest (L/T)

- A = interfacial surface area between water and adjacent air (L<sup>2</sup>)
- k<sub>l</sub> = liquid-phase mass transfer coefficient (L/T)
- k<sub>g</sub> = gas-phase mass transfer coefficient (L/T)
- H<sub>c</sub> = Henry's law constant for chemical of interest (L<sup>3</sup><sub>liq</sub>/L<sup>3</sup><sub>gas</sub>).

In accordance with two-film theory (Lewis and Whitman, 1924), liquid- and gas-phase mass transfer coefficients are related to chemical properties and fluid flow conditions as follows:

$$k_l = \frac{D_l}{\delta_l} \quad (2-6)$$

$$k_g = \frac{D_g}{\delta_g} \quad (2-7)$$

where

- k<sub>l</sub> = liquid-phase mass transfer coefficient (L/T)
- k<sub>g</sub> = gas-phase mass transfer coefficient (L/T)
- D<sub>l</sub> = molecular diffusion coefficient for a chemical in water (L<sup>2</sup>/T)
- D<sub>g</sub> = molecular diffusion coefficient for a chemical in air (L<sup>2</sup>/T)
- δ<sub>l</sub> = thickness of a hypothetical liquid film adjacent to the interface and through which chemical transport is solely by molecular diffusion (L)
- δ<sub>g</sub> = thickness of a hypothetical gas film adjacent to the interface and through which chemical transport is solely by molecular diffusion (L).

Molecular diffusion coefficients vary to some extent between volatile chemicals and are a function of fluid temperature. The hypothetical film thicknesses are assumed to be a function of the extent of turbulent kinetic energy and subsequent mixing on either side of the interface, decreasing in width with an increase in turbulent kinetic energy. For dilute aqueous solutions, the film thicknesses are assumed to be independent of chemical concentrations.

For penetration theory (Higbie, 1935) and surface renewal theory (Danckwerts, 1951), liquid- and gas-phase mass transfer coefficients are predicted to be proportional to the product of molecular diffusion coefficients and surface renewal rates according to:

$$k_l \propto (D_l r_l)^{0.5} \quad (2-8)$$

$$k_g \propto (D_g r_g)^{0.5} \quad (2-9)$$

where

- $k_l$  = liquid-phase mass transfer coefficient (L/T)
- $k_g$  = gas-phase mass transfer coefficient (L/T)
- $D_l$  = molecular diffusion coefficient for a chemical in water (L<sup>2</sup>/T)
- $D_g$  = molecular diffusion coefficient for a chemical in air (L<sup>2</sup>/T)
- $r_l$  = rate of surface renewal for the liquid side of the interface (1/T)
- $r_g$  = rate of surface renewal for the gas side of the interface (1/T).

The hypothetical surface renewal rates are assumed to be independent of contaminant concentrations for dilute aqueous solutions. They are assumed to increase as turbulent kinetic energy in the bulk fluid increases.

Finally, Dobbins (1956) developed a theory (film-penetration theory) that incorporates the fundamental principles of both two-film and penetration theories. Corresponding relationships for  $k_l$  and  $k_g$  are:

$$k_l \propto (D_l r_l)^{\frac{1}{2}} \coth \left( \frac{r_l \bar{a}_l^2}{D_l} \right)^{\frac{1}{2}} \quad (2-10)$$

$$k_g \propto (D_g r_g)^{\frac{1}{2}} \coth \left( \frac{r_g \bar{a}_g^2}{D_g} \right)^{\frac{1}{2}} \quad (2-11)$$

where

- $k_l$  = liquid-phase mass transfer coefficient (L/T)
- $k_g$  = gas-phase mass transfer coefficient (L/T)
- $D_l$  = molecular diffusion coefficient for a chemical in water (L<sup>2</sup>/T)
- $D_g$  = molecular diffusion coefficient for a chemical in air (L<sup>2</sup>/T)
- $\bar{a}_l$  = thickness of a hypothetical liquid film adjacent to the interface and through which chemical transport is solely by molecular diffusion (L)
- $\bar{a}_g$  = thickness of a hypothetical gas film adjacent to the interface and through which chemical transport is solely by molecular diffusion (L)
- $r_l$  = rate of surface renewal for the liquid side of the interface (1/T)

$r_g$  = rate of surface renewal for the gas side of the interface (1/T).

Film-penetration theory reduces to two-film theory as  $r_l$  and  $r_g$  become small, and to penetration theory as  $r_l$  and  $r_g$  become large.

Although values of hypothetical film thicknesses or surface renewal rates are not readily measurable, Equations 2-6 through 2-11 are fundamental for relating mass transfer coefficients between chemicals. Because the influences of hydrodynamic characteristics ( $\bar{a}$  or  $r$ ) are independent of chemical concentrations or characteristics in dilute aqueous solutions, the ratio of liquid-phase mass transfer coefficients for two compounds can be expressed as:

$$\varnothing_i = \frac{k_{li}}{k_{lj}} \frac{k_{li}A}{k_{lj}A} \left\{ \frac{D_{li}}{D_{lj}} \right\}^{n_i} \quad (2-12)$$

where

- $\varnothing_i$  = liquid-phase mass transfer relational parameter (-)
- $k_{li}$  = liquid-phase mass transfer coefficient for chemical i (L/T)
- $k_{lj}$  = liquid-phase mass transfer coefficient for chemical j (L/T)
- $A$  = interfacial surface area between water and adjacent air ( $L^2$ )
- $D_{li}$  = liquid-phase diffusion coefficient for chemical i ( $L^2/T$ )
- $D_{lj}$  = liquid-phase diffusion coefficient for chemical j ( $L^2/T$ )
- $n_i$  = liquid-phase power constant (-).

The power constant  $n_i$  varies from 0.5 (penetration and surface renewal theory) to 1.0 (two-film theory). Values of  $n_i$  have been calculated for natural and engineered systems and are often reported to be between 0.6 and 0.7 (Roberts et al., 1984; Smith et al., 1980). A value of 2/3 is commonly applied. Given a specific value of  $n_i$ , Equation 2.12 can be used to estimate  $k_{li}$ , given a measured or estimated  $k_{lj}$  and the ratio of liquid-phase diffusion coefficients between i and j. The latter are generally available for many volatile chemicals and may also be estimated with a reasonable degree of accuracy (Tucker and Nelken, 1990). Although  $D_{li}$  and  $D_{lj}$  are both functions of temperature, researchers have observed that  $\varnothing_i$  does not vary significantly with variations in water temperature, occurrence of surfactants, or degree of turbulent mixing, although the latter may cause variations in  $n_i$  (decreasing with an increase in the amount of turbulent kinetic energy in the water) (Matter-Muller et al., 1981; Smith et al., 1980).

In a manner similar to that for  $k_{li}$  and  $k_{lj}$ , the ratio of gas-phase mass transfer coefficients for two compounds can be expressed as:

$$\varnothing_g = \frac{k_{gi}}{k_{gj}} \left\{ \frac{D_{gi}}{D_{gj}} \right\}^{n_2} \quad (2-13)$$

where

- $\varnothing_g$  = gas-phase mass transfer relational parameter (-)
- $k_{gi}$  = gas-phase mass transfer coefficient for chemical i (L/T)
- $k_{gj}$  = gas-phase mass transfer coefficient for chemical j (L/T)
- $D_{gi}$  = gas-phase diffusion coefficient for chemical i ( $L^2/T$ )
- $D_{gj}$  = gas-phase diffusion coefficient for chemical j ( $L^2/T$ )
- $n_2$  = power constant (-).

As with the power constant  $n_1$ ,  $n_2$  varies between 0.5 and 1.0. Relative to studies involving estimates of  $n_1$ , less work has been reported to confirm appropriate values of  $n_2$ . A value of  $n_2$  equal to 2/3 is often assumed (Little, 1992).

In accordance with Equation 2-4, the ratio of overall mass transfer coefficients for chemicals i and j can be expressed as:

$$\varnothing_m = \frac{K_{Li}}{K_{Lj}} \cdot \frac{\frac{1}{k_{lj}} \frac{1}{k_{gj} CH_{cj}}}{\frac{1}{k_{li}} \frac{1}{k_{gi} CH_{ci}}} \cdot \frac{\frac{1}{k_{lj} A} \frac{1}{k_{gj} A CH_{cj}}}{\frac{1}{k_{li} A} \frac{1}{k_{gi} A CH_{ci}}} \quad (2-14)$$

where

- $K_{Li}$  = overall mass transfer coefficient for chemical i (L/T)
- $K_{Lj}$  = overall mass transfer coefficient for chemical j (L/T)
- $A$  = interfacial surface area between water and adjacent air ( $L^2$ )
- $k_{li}$  = liquid-phase mass transfer coefficient for chemical i (L/T)
- $k_{lj}$  = liquid-phase mass transfer coefficient for chemical j (L/T)
- $k_{gi}$  = gas-phase mass transfer coefficient for chemical i (L/T)
- $k_{gj}$  = gas-phase mass transfer coefficient for chemical j (L/T)
- $H_{ci}$  = Henry's law constant for chemical i ( $L^3_{liq}/L^3_{gas}$ )
- $H_{cj}$  = Henry's law constant for chemical j ( $L^3_{liq}/L^3_{gas}$ ).

Assuming  $k_{gj}/k_{lj}$  is equal to  $k_{gi}/k_{li}$ , Equation 2-14 can be rearranged algebraically to yield:

$$\emptyset_m \cdot \frac{K_{Li}}{K_{Lj}} \cdot \emptyset_l \emptyset_g \left( \frac{H_{ci}}{H_{cj}} \right) \left( \frac{1 + \frac{k_{gj}}{k_{lj}} H_{cj}}{\emptyset_l \emptyset_g H_{ci} \frac{k_{gj}}{k_{lj}}} \right) \quad (2-15)$$

where

$\emptyset_m$  = overall mass transfer coefficient relational parameter (-)

$K_{Li}$  = overall mass transfer coefficient for chemical i (L/T)

$K_{Lj}$  = overall mass transfer coefficient for chemical j (L/T)

$\emptyset_l$  = liquid-phase mass transfer relational parameter (-)  $\cdot \left( \frac{D_{li}}{D_{lj}} \right)^{n_1}$

$D_{li}$  = liquid-phase diffusion coefficient for chemical i ( $L^2/T$ )

$D_{lj}$  = liquid-phase diffusion coefficient for chemical j ( $L^2/T$ )

$n_1$  = liquid-phase power constant (-)

$\emptyset_g$  = gas-phase mass transfer relational parameter (-)  $\cdot \left( \frac{D_{gi}}{D_{gj}} \right)^{n_2}$

$D_{gi}$  = gas-phase diffusion coefficient for chemical i ( $L^2/T$ )

$D_{gj}$  = gas-phase diffusion coefficient for chemical j ( $L^2/T$ )

$n_2$  = power constant (-)

$H_{ci}$  = Henry's law constant for chemical i ( $L^3_{liq}/L^3_{gas}$ )

$H_{cj}$  = Henry's law constant for chemical j ( $L^3_{liq}/L^3_{gas}$ )

$k_{lj}$  = liquid-phase mass transfer coefficient for chemical j (L/T)

$k_{gj}$  = gas-phase mass transfer coefficient for chemical j (L/T).

A common mistake when relating overall mass transfer coefficients between two chemicals is to assume that  $K_{Li}/K_{Lj} = \emptyset_l$ . This relationship requires knowledge only of liquid molecular diffusion coefficients for each compound in accordance with Equation 2-12, but is valid only when gas-phase resistance to mass transfer is negligible for each compound. In fact, Equation 2-15 converges to



Equation 2-12 as  $k_g/k_l$  and/or  $H_c$  for both  $i$  and  $j$  become very large. As discussed previously, an assumption that gas-phase resistance is negligible is reasonable when both compounds are highly volatile (e.g., radon). However, for less volatile compounds, it may be necessary to know or estimate not only liquid-phase molecular diffusion coefficients, but also gas-phase molecular diffusion coefficients, Henry's law constants for each chemical, and the ratio of gas-to-liquid phase mass transfer coefficients for the relational surrogate  $j$ . Diffusion coefficients and Henry's law constants can be readily obtained or estimated for most chemicals. However, there has not been a significant amount of published information related to  $k_g/k_l$  for indoor sources, including its variability with source operating conditions (e.g., liquid flowrate). Thus, an objective of this project was to determine values of  $k_gA$ ,  $k_lA$ , and  $k_g/k_l$  for a wide range of operating conditions associated with each experimental system.

## 2.2. IDEAL REACTOR MODELS

Three ideal reactor models are often used to simulate aqueous and gaseous systems. First, a system may behave as an ideal plug flow reactor (PFR) in which fluid parcels move in an orderly manner without any contact of other fluid parcels in the axial direction, that is, no axial dispersion. A second ideal reactor is a continuous-flow stirred-tank reactor (CFSTR), where fluid parcels are completely mixed within the system such that the concentration within the reactor is the same at all locations. The influent stream of a CFSTR is instantaneously mixed with fluid in the reactor, and the exit stream has the same concentration as fluid within the reactor. Finally, an ideal batch reactor may be used to describe systems where fluid is initially introduced to a system as a well-mixed uniform solution, after which no fluid enters or leaves the reactor. Most household water systems have behavior that falls between these ideal cases. However, instead of developing nonideal flow models, for this project each experimental system was analyzed as though it were ideal. Deviations from the assumed ideal case are reflected in the experimentally determined mass transfer coefficients.

### 2.2.1. Plug Flow Reactor Model

A schematic of a plug flow reactor is shown in Figure 2-1. The associated mass balance equation for a differential element of volume  $\Delta V$  is:

$$\frac{d(CV)}{dt} = (QC)|_z - (QC)|_{z+\Delta z} + \sum r_v \Delta V + \sum r_A \Delta A \quad (2-16)$$

where

$C$	=	chemical concentration ( $M/L^3$ )
$V$	=	volume ( $L^3$ )
$t$	=	time (T)

- $\Delta A$  = differential area ( $L^2$ )
- $Q$  = volumetric flowrate ( $L^3/T$ )
- $r_V$  = volume reaction rate ( $M/L^3CT$ )
- $\Delta V$  = differential volume ( $L^3$ )
- $r_A$  = area reaction rate ( $M/L^2CT$ )
- $z$  = direction of flow.

### 2.2.2. Continuous-Flow Stirred-Tank Reactor Model

The following equation applies to the CFSTR depicted in Figure 2-2:

$$\frac{d(CV)}{dt} = \sum_{i=1}^n Q_{jn,j} C_{jn,j} - Q_{out,total} C + \overset{\circ}{a} r_{V,j} V + \overset{\circ}{a} r_{A,j} A_j \quad (2-17)$$

where

- $C$  = chemical concentration in reactor ( $M/L^3$ )
- $V$  = volume ( $L^3$ )
- $Q_{in}$  = inlet volumetric flowrate ( $L^3/T$ )
- $C_{in}$  = inlet chemical concentration ( $M/L^3$ )
- $Q_{out}$  = outlet volumetric flowrate ( $L^3/T$ )
- $r_V$  = volume reaction rate ( $M/L^3CT$ )
- $r_A$  = area reaction rate ( $M/L^2CT$ )
- $A$  = area ( $L^2$ ).

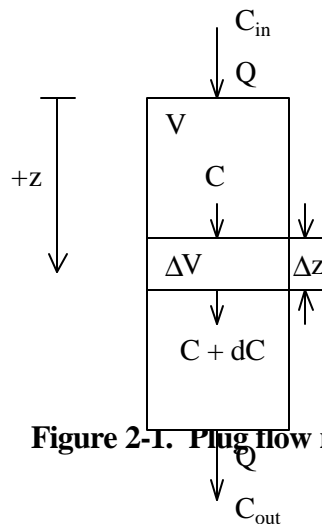
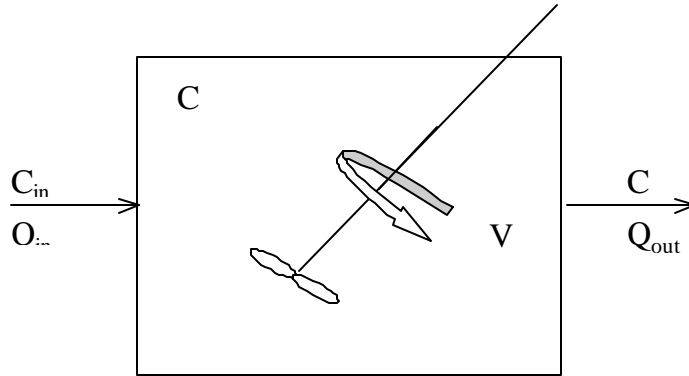

Figure 2-1. Plug flow reactor.



**Figure 2-2. Continuous-flow stirred-tank reactor.**

### 2.2.3. Batch Reactor Model

A batch reactor is merely a simplified CFSTR, that is, a well-mixed solution with no volumetric flowrate terms. A mass balance on the batch reactor shown in Figure 2-3 is:

$$\frac{d(CV)}{dt} = a^p r_{v,j} V + a^q r_{A,j} A_j \quad (2-18)$$

where

- C = chemical concentration in reactor (M/L<sup>3</sup>)
- V = volume (L<sup>3</sup>)
- r<sub>v</sub> = volume reaction rate (M/L<sup>3</sup>CT)
- r<sub>A</sub> = area reaction rate (M/L<sup>2</sup>CT)
- A = area (L<sup>2</sup>).

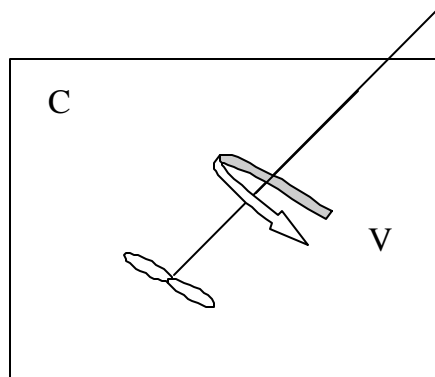

**Figure 2-3. Batch reactor.**

## 2.3. SOURCE-SPECIFIC MASS BALANCE MODELS

Development of source-specific mass balance models involved the following steps: (1) defining the system's phase boundaries and (2) determining which ideal flow model most accurately represented each phase. The mass balances for each source, as well as solutions to the resulting differential equations, are given in this section.

### 2.3.1. Dishwasher Models

Dishwasher operation consists of pumping hot water through a rotating spray arm that produces liquid droplets that impact surrounding surfaces. The volume of liquid used in operation is recycled, that is, the liquid volume is constant. Typical dishwasher operation consists of four cycles: prerinse, wash, rinse, and final rinse. Within each cycle is a fill period, the cycling of water, and a drain period. The fill and drain periods are significantly shorter (100 seconds each) than the cycling of water, and were not modeled for this study.

Figure 2-4 represents a dishwasher, for which the liquid phase is treated as a well-mixed batch reactor. Chemical volatilization is primarily due to the formation and spraying of droplets. Following Equation 2-18 with the only reaction term being the transfer of mass across the water/air interface (see Equation 2-3), a mass balance on the liquid phase leads to:

$$\frac{d(C_1 V_1)}{dt} = -K_L C_1 - \frac{C_g}{H_c} A \quad (2-19)$$

where

- $C_1$  = chemical concentration in water ( $M/L^3$ )
- $V_1$  = volume of water ( $L^3$ )
- $t$  = time (T)
- $K_L$  = overall mass transfer coefficient for the chemical of interest (L/T)
- $C_g$  = chemical concentration in air adjacent to water ( $M/L^3$ )
- $H_c$  = Henry's law constant for chemical of interest ( $L^3_{liq}/L^3_{gas}$ )
- $A$  = interfacial surface area between water and adjacent air ( $L^2$ ).

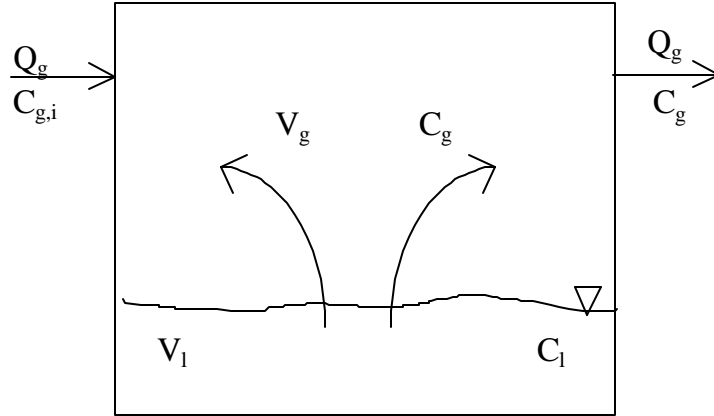

**Figure 2-4. Dishwasher model.**

Assuming the liquid volume is constant during operation, the liquid-phase mass balance may be rewritten as:

$$\frac{dC_1}{dt} = -\frac{K_L A}{V_1} C_1 + \frac{K_L A}{V_1 H_c} C_g \quad (2-20)$$

where

- $C_1$  = chemical concentration in water ( $M/L^3$ )
- $V_1$  = volume of water ( $L^3$ )
- $t$  = time (T)
- $K_L$  = overall mass transfer coefficient for the chemical of interest (L/T)
- $C_g$  = chemical concentration in air adjacent to water ( $M/L^3$ )
- $H_c$  = Henry's law constant for chemical of interest ( $L^3_{liq}/L^3_{gas}$ )
- $A$  = interfacial surface area between water and adjacent air ( $L^2$ ).

The dishwasher headspace (gas phase) is assumed to approach a CFSTR, also with a single reaction term related to mass transfer across the water/air interface. A corresponding mass balance leads to:

$$\frac{d(C_g V_g)}{dt} = Q_g C_{g,in} - Q_g C_g + K_L C_1 - \frac{C_g}{H_c} A \quad (2-21)$$

where

- $C_g$  = chemical concentration in air adjacent to water ( $M/L^3$ )
- $V_g$  = headspace volume ( $L^3$ )

- $t$  = time (T)  
 $Q_g$  = ventilation rate ( $L^3/T$ )  
 $C_{g,in}$  = gas concentration entering system from outside air ( $M/L^3$ )  
 $K_L$  = overall mass transfer coefficient for the chemical of interest ( $L/T$ )  
 $C_1$  = chemical concentration in water ( $M/L^3$ )  
 $H_c$  = Henry's law constant for chemical of interest ( $L^3_{liq}/L^3_{gas}$ )  
 $A$  = interfacial surface area between water and adjacent air ( $L^2$ ).

Assuming the gas volume is constant during operation and the background air is relatively clean ( $C_{g,in} = 0$ ), Equation 2-21 may be rewritten as:

$$\frac{dC_g}{dt} = \frac{K_L A}{V_g} C_1 - \frac{Q_g}{V_g} C_g + \frac{K_L A}{V_g H_c} C_g \quad (2-22)$$

where

- $C_g$  = chemical concentration in air adjacent to water ( $M/L^3$ )  
 $V_g$  = headspace volume ( $L^3$ )  
 $t$  = time (T)  
 $Q_g$  = ventilation rate ( $L^3/T$ )  
 $K_L$  = overall mass transfer coefficient for the chemical of interest ( $L/T$ )  
 $C_1$  = chemical concentration in water ( $M/L^3$ )  
 $H_c$  = Henry's law constant for chemical of interest ( $L^3_{liq}/L^3_{gas}$ )  
 $A$  = interfacial surface area between water and adjacent air ( $L^2$ ).

Equations 2-20 and 2-22 must be solved simultaneously in order to determine  $K_L A$ .

Analysis using Laplace transforms leads to:

$$C_i' C_{i,0} \left[ \exp\left(\frac{D}{2} t\right) \cosh\left(\left(\sqrt{\frac{D^2}{4} + E}\right) t\right) \right] \quad (2-23)$$

and

$$\left( \frac{BF}{Z} + \frac{EC_{i,0}}{Z} + \frac{DC_{i,0}}{2} \right) \left[ \frac{1}{\sqrt{\frac{D^2}{4} + E}} \exp\left(\frac{D}{2} t\right) \sinh\left(\left(\sqrt{\frac{D^2}{4} + E}\right) t\right) \right]$$

$$C_g = C_{g,0} \exp\left(-\frac{D}{2}t\right) \cosh\left(\sqrt{\frac{D^2}{4} + E}t\right) + \left(F + \frac{DC_{g,0}}{2}\right) \left[ \frac{1}{\sqrt{\frac{D^2}{4} + E}} \exp\left(-\frac{D}{2}t\right) \sinh\left(\sqrt{\frac{D^2}{4} + E}t\right) \right] \quad (2-24)$$

where

$C_{l,0}$  = initial liquid concentration (M/L<sup>3</sup>)

$C_{g,0}$  = initial gas concentration (M/L<sup>3</sup>)

$$Z = \frac{K_L A}{V_l}$$

$K_L$  = overall mass transfer coefficient for the chemical of interest (L/T)

$A$  = interfacial surface area between water and adjacent air (L<sup>2</sup>)

$V_l$  = volume of water (L<sup>3</sup>)

$$B = \frac{K_L A}{V_l H_c}$$

$H_c$  = Henry's law constant for chemical of interest (L<sup>3</sup><sub>liq</sub>/L<sup>3</sup><sub>gas</sub>)

$$X = \frac{K_L A}{V_g}$$

$V_g$  = headspace volume (L<sup>3</sup>)

$$Y = \frac{Q_g}{V_g} \frac{K_L A}{V_g H_c}$$

$Q_g$  = ventilation rate (L<sup>3</sup>/T)

$D = Z + Y$

$E = ZY - BX$

$F = ZC_{g,0} + XC_{l,0}$

The method used to determine  $K_L A$  based on experimental data is presented in Section 3.6.

### 2.3.2. Washing Machine Models

Typical operation of a residential washing machine consists of the following sequence of events: fill, wash, spin, fill, rinse, and spin. The fill cycle consists of a falling film that impacts an underlying pool that continuously increases in depth. Chemical volatilization may be attributed to the falling film, splashing at the surface, and entrained air bubbles. The wash and rinse cycles both involve agitation of the basin water for a specific length of time. The only differences between the wash and rinse cycles are the presence of detergent for the wash cycle and the time of agitation. The primary mass transfer mechanism associated with these cycles is volatilization across the agitated water/air interface. Finally, during a spin cycle the washing machine basket is rotated at a rapid rate such that the respective wash and rinse water is removed from the clothing and pumped from the machine. It was assumed that minimal chemical volatilization occurs during a spin cycle because of lower water volume and shorter contact time between the contaminated water and headspace air. The rate of chemical volatilization from a washing machine was characterized through independent investigations of the fill and wash/rinse cycles.

#### 2.3.2.1. Washing Machine Fill Cycle

A washing machine fill cycle is represented in Figure 2-5. Water enters a machine with a constant inlet concentration and accumulates in the washing machine basin. On the basis of visual observation of turbulence in the underlying pool and a short residence time for the falling film, volatilization from the latter was assumed to be insignificant. A mass balance on the liquid phase is based on a CFSTR such that:

$$\frac{d(C_1 V_1)}{dt} = Q_1 C_{1,in} - K_L C_1 - \frac{C_g}{H_c} A \quad (2-25)$$

where

- $C_1$  = chemical concentration in water ( $M/L^3$ )
- $V_1$  = volume of water ( $L^3$ )
- $t$  = time (T)
- $Q_1$  = liquid fill rate ( $L^3/T$ )
- $C_{1,in}$  = inlet liquid-phase concentration ( $M/L^3$ )
- $K_L$  = overall mass transfer coefficient for the chemical of interest (L/T)
- $C_g$  = chemical concentration in air adjacent to water ( $M/L^3$ )
- $H_c$  = Henry's law constant for chemical of interest ( $L^3_{liq}/L^3_{gas}$ )
- $A$  = interfacial surface area between water and adjacent air ( $L^2$ ).



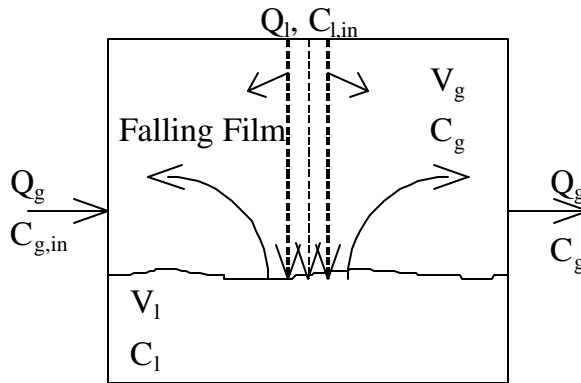

Figure 2-5. Washing machine fill cycle model.

The gas phase of the system is also assumed to approach a continuous-flow stirred-tank reactor. A corresponding mass balance leads to:

$$\frac{d(C_g V_g)}{dt} = Q_g C_{g,in} - Q_g C_g + K_L \left( C_1 - \frac{C_g}{H_c} \right) A \quad (2-26)$$

where

- $C_g$  = chemical concentration in air adjacent to water ( $M/L^3$ )
- $V_g$  = headspace volume ( $L^3$ )
- $t$  = time (T)
- $Q_g$  = ventilation rate ( $L^3/T$ )
- $C_{g,in}$  = gas concentration entering system from outside air ( $M/L^3$ )
- $K_L$  = overall mass transfer coefficient for the chemical of interest (L/T)
- $C_1$  = chemical concentration in water ( $M/L^3$ )
- $H_c$  = Henry's law constant for chemical of interest ( $L^3_{liq}/L^3_{gas}$ )
- $A$  = interfacial surface area between water and adjacent air ( $L^2$ ).

As with the gas-phase mass balance for dishwashers, Equation 2-26 may be simplified by assuming that the background air is relatively clean. However, unlike the dishwasher gas-phase mass balance, the washing machine gas-phase volume is changing with time as the liquid fills the machine and must therefore remain as part of the derivative.

In order to determine  $K_L A$  during filling, Equations 2-25 and 2-26 were solved simultaneously. However, since the liquid and gas-phase volumes and chemical concentrations

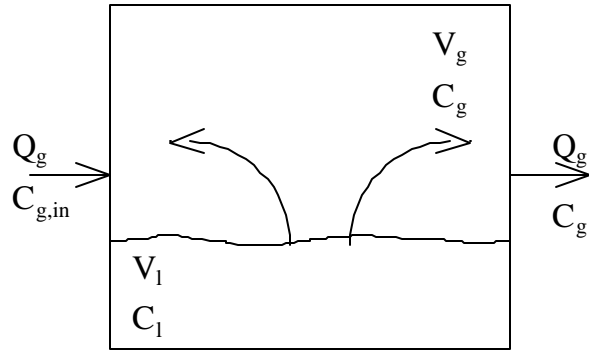

**Figure 2-6. Washing machine wash/rinse cycle model.**

are changing with time, a numerical solution technique was adopted to determine  $K_L A$ . This method is presented in Section 3.6.

### 2.3.2.2. Washing Machine Wash/Rinse Cycles

The liquid phase for a wash/rinse cycle was treated as a well-mixed batch reactor with a constant liquid volume (Figure 2-6). The liquid- and gas-phase mass balances for this system are identical to the liquid- and gas-phase mass balances for a dishwasher (Equations 2-20 and 2-22). Thus, the solutions given in Equations 2-23 and 2-24 also apply for this source.

### 2.3.3. Shower Models

Mass balance equations for a shower (as shown in Figure 2-7) were developed previously by Little (1992). A summary of these equations, and their derivation, is provided in the text below.

Little (1992) identified the regions within a shower system where mass transfer occurs: drop formation, drop acceleration to terminal velocity, fall of drop at terminal velocity, and impact of drop on shower stall surfaces. To predict the rate of mass transfer from liquid droplets to the surrounding air, Little modeled the liquid phase as a plug-flow system with the following mass balance:

$$\frac{dC_l}{dz} = - \frac{K_L \left( C_l - \frac{C_g}{H_c} \right) P}{Q_l} \quad (2-27)$$

where

- $C_l$  = chemical concentration in water ( $M/L^3$ )
- $K_L$  = overall mass transfer coefficient for the chemical of interest ( $L/T$ )
- $C_g$  = chemical concentration in air adjacent to water ( $M/L^3$ )

- $H_c$  = Henry's law constant for chemical of interest ( $L^3_{liq}/L^3_{gas}$ )
- $Q_l$  = liquid flowrate ( $L^3/T$ )
- $z$  = direction of flow
- $P$  = perimeter of water stream (L).

The residence time of a water droplet was assumed to be relatively short. This assumption allowed the gas-phase concentration in Equation 2-27 to be considered constant. The resulting differential equation was solved to give:

$$C_{l,out} = C_{l,0} \exp\left\{-\frac{K_L A}{Q_l}\right\} \left(\frac{C_g}{H_c}\right) \left(1 + \exp\left\{-\frac{K_L A}{Q_l}\right\}\right) \quad (2-28)$$

where

- $C_{l,out}$  = outlet chemical concentration in water ( $M/L^3$ )
- $C_{l,in}$  = inlet chemical concentration in water ( $M/L^3$ )
- $K_L$  = overall mass transfer coefficient for the chemical of interest ( $L/T$ )
- $PL$  = interfacial area ( $L^2$ )
- $P$  = perimeter of water stream (L)
- $L$  = length of stream of water (L)

**Figure 2-7. Shower model.**

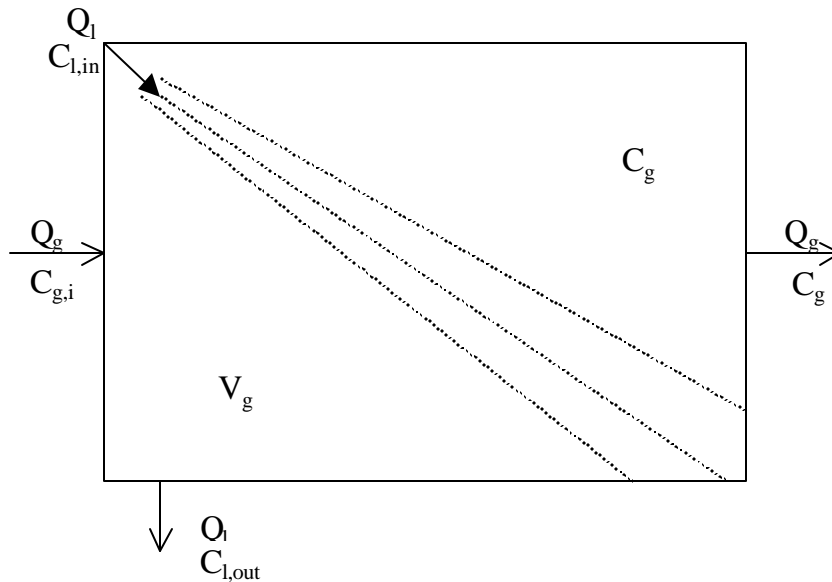

- $Q_l$  = liquid flowrate ( $L^3/T$ )

- $C_g$  = chemical concentration in air adjacent to water (M/L<sup>3</sup>)  
 $H_c$  = Henry's law constant for chemical of interest (L<sup>3</sup><sub>liq</sub>/L<sup>3</sup><sub>gas</sub>).

Little (1992) also developed a mass balance to characterize the change in gas-phase concentration during shower operation. He modeled the gas phase as a CFSTR with the transfer of mass from the liquid being the difference between the mass flowrate of chemical entering the system and the mass flowrate of chemical leaving the system ( $Q_l C_{l,in} - Q_l C_{l,out}$ ). The following equation was applied:

$$V_g \frac{dC_g}{dt} = Q_l (C_{l,0} - C_{l,out}) - Q_g (C_g - C_{g,0}) \quad (2-29)$$

where

- $C_g$  = chemical concentration in air adjacent to water (M/L<sup>3</sup>)  
 $V_g$  = shower stall volume (L<sup>3</sup>)  
 $t$  = time (T)  
 $Q_l$  = liquid flowrate (L<sup>3</sup>/T)  
 $C_{l,in}$  = inlet chemical concentration in water (M/L<sup>3</sup>)  
 $C_{l,out}$  = outlet chemical concentration in water (M/L<sup>3</sup>)  
 $Q_g$  = ventilation rate (L<sup>3</sup>/T)  
 $C_{g,in}$  = inlet chemical concentration in air (M/L<sup>3</sup>).

The solution to the gas-phase mass balance was achieved by substituting Equation 2-28 into Equation 2-29 and then integrating, to yield:

$$C_g = \frac{B}{D} \left( C_{g,0} + \frac{B}{D} \right) \exp(-Dt) \quad (2-30)$$

where

- $C_{g,0}$  = initial gas concentration (M/L<sup>3</sup>)  
 $t$  = time (T)

$$B = \frac{Q_l C_{l,0} \left( 1 + \exp\left(\frac{K_L A}{Q_l}\right) \right) - Q_g C_{g,0}}{V_g} \quad (M/L^3 CT)$$

- $Q_l$  = liquid flowrate (L<sup>3</sup>/T)  
 $C_{l,in}$  = inlet chemical concentration in water (M/L<sup>3</sup>)

$K_L$  = overall mass transfer coefficient for the chemical of interest (L/T)

$A$  = interfacial area ( $L^2$ )

$Q_g$  = ventilation rate ( $L^3/T$ )

$C_{g,in}$  = inlet chemical concentration in air ( $M/L^3$ )

$V_g$  = shower stall volume ( $L^3$ )

$$D = \frac{\left( \left( \frac{Q_l}{H_c} \right) \left( 1 + \exp \left( \frac{K_L A}{Q_l} \right) \right) \% Q_g \right)}{V_g} \quad (1/T)$$

$H_c$  = Henry's law constant for chemical of interest ( $L^3_{liq}/L^3_{gas}$ ).

Values of  $K_L A$  may be estimated using Equations 2-28 and 2-30. The corresponding solution technique is presented in Section 3.6.

### 2.3.4. Bathtub Models

Three distinct operations are associated with a bathtub: (1) water flowing through the faucet with the drain open (flow-through), (2) filling the tub, and (3) bathing in a filled tub. Each operation has a different associated mass balance model.

#### 2.3.4.1. Bathtub Flow-Through Model

When water is flowing through the faucet with the drain open, there is no accumulation of water in the basin. This type of operation is depicted in Figure 2-8 and may be treated in a manner similar to that of a shower, such that Equations 2-27 and 2-29 apply.

#### 2.3.4.2. Bathtub Fill Model

The filling of a bathtub (Figure 2-9) is similar to the washing machine fill cycle, whose mass balance equations were given in Section 2.3.2.1. The numerical solution technique adopted for a bathtub is provided in Section 3.6.

#### 2.3.4.3. Bathtub Surface Volatilization Model

Finally, once the tub is filled, chemical mass transfer may continue across the water/air interface. As shown in Figure 2-10, there are no more inputs or outputs of mass, such that the system may be modeled in a manner similar to that of a dishwasher (see Section 2.3.1) and washing machine wash/rinse cycles (see Section 2.3.2.2).

## 2.4. CHEMICAL EMISSION MODELS

A valuable product of this work is the ability to predict human inhalation exposure to contaminants present in drinking water. The level of human exposure is directly related to the gas-phase chemical concentration, which may be estimated using the appropriate source-specific mass balance models presented in Section 2.3. In addition to  $C_g$ , system and environmental conditions are also important for predicting human exposure, for example, room volume, air exchange rate, or headspace ventilation rate.

For dishwashers and washing machines, humans are exposed to chemicals emitted from the headspace within each respective machine. This emission rate is equivalent to:

$$E_{\text{chem}} = Q_g C_{g,t} \quad (2-31)$$

**Figure 2-8. Bathtub flow-through model.**

**Figure 2-9. Bathtub fill model.**

**Figure 2-10. Bathtub surface volatilization model.**

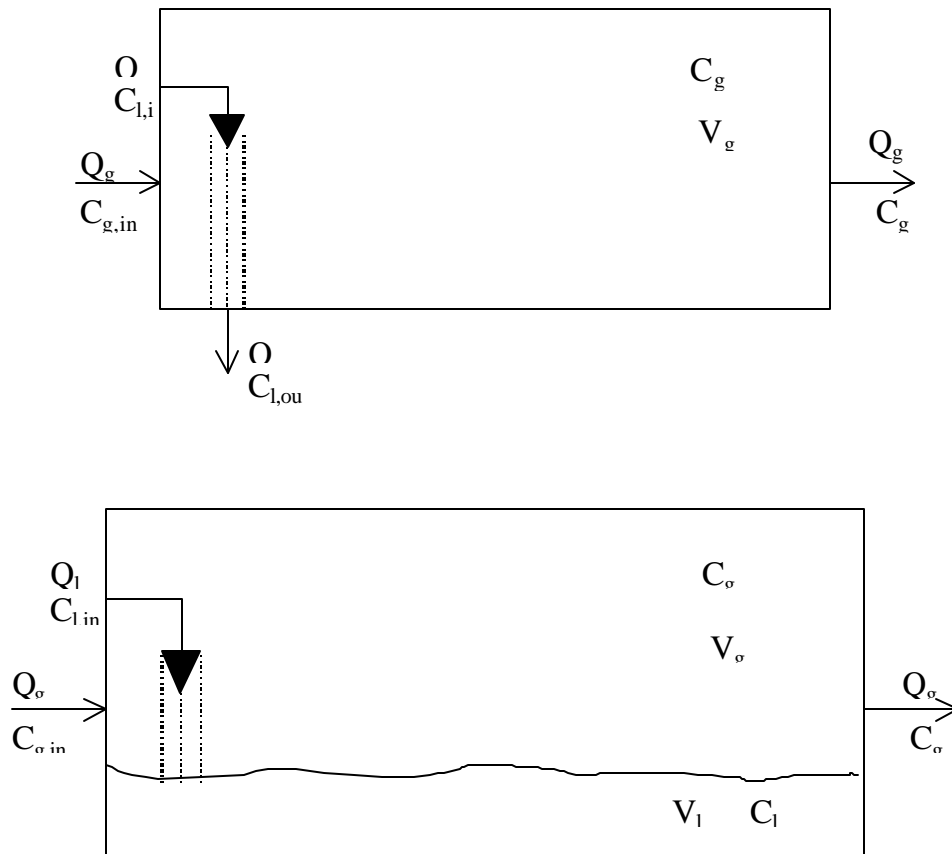

where

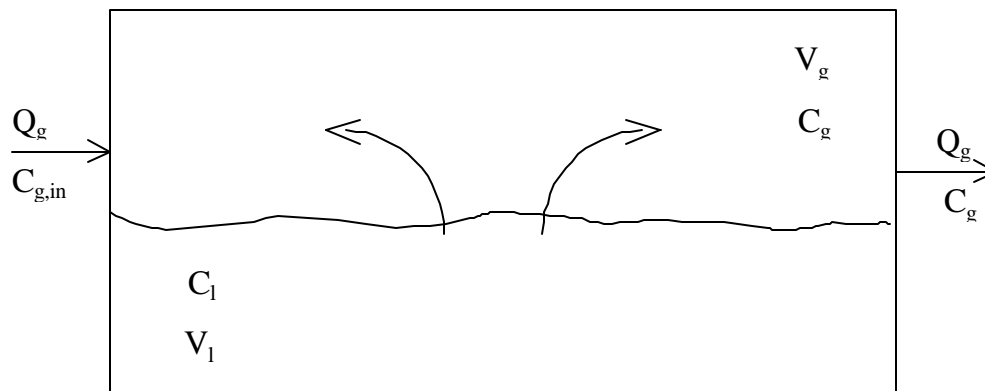

- $E_{\text{chem}}$  = chemical mass emission rate (M/T)
- $Q_g$  = machine headspace ventilation rate ( $L^3/T$ )
- $C_{g,t}$  = time-dependent gas-phase chemical concentration in machine headspace ( $M/L^3$ ).

Equation 2-31 may be used to estimate a chemical mass emission rate profile for the duration of machine operation. Integration under this curve results in total chemical mass emitted during the event. Resulting human exposure may be predicted by incorporating the mass emission rate profile into a mass balance on the associated room air. An application of these models is presented in Chapter 8.

In showers and bathtubs, humans receive a more “direct” exposure to volatilized chemicals. Assuming no other losses, the mass flowrate for a plug-flow system is equivalent to:

$$E_{\text{chem}} = Q_l (C_{l,\text{in}} - C_{l,\text{out}}) \quad (2-32)$$

where

- $E_{\text{chem}}$  = chemical mass emission rate (M/T)
- $Q_l$  = liquid flowrate ( $L^3/T$ )
- $C_{l,\text{in}}$  = liquid-phase concentration entering system ( $M/L^3$ )
- $C_{l,\text{out}}$  = liquid-phase concentration leaving system ( $M/L^3$ ).

Mass emissions during a bathing event may be determined using:

$$E_{\text{chem}} = K_L A \left( C_l - \frac{C_g}{H_c} \right) \quad (2-33)$$

where

- $E_{\text{chem}}$  = chemical mass emission rate (M/T)
- $K_L$  = overall mass transfer coefficient for the chemical of interest (L/T)
- $A$  = interfacial area ( $L^2$ )
- $C_1$  = chemical concentration in water ( $M/L^3$ )
- $C_g$  = chemical concentration in air adjacent to water ( $M/L^3$ )
- $H_c$  = Henry's law constant for chemical of interest ( $L^3_{\text{liq}}/L^3_{\text{gas}}$ ).

As with dishwashers and washing machines, the mass emission rate profile may be developed for the duration of a showering or bathing event. Example applications of mass emission models are presented in Chapter 8.